

Photoreceiver of a rangefinder operating within eyesafe radiation range

Z. BIELECKI*, K. CHMIELEWSKI, T. PIĄTKOWSKI, and E. POWIADA

Institute of Optoelectronics, Military University of Technology
2 Kaliskiego Str., 00-908 Warsaw, Poland

The paper presents a photoreceiver of the rangefinder operating within eyesafe radiation range. Main subsystems of the photoreceiver were analysed. Computer simulation of the photoreceiver was made and its results were coincident with the experimental ones. Original system enabling an automatic control of the comparator threshold was used. A system for power supply and stabilisation of the working point of an avalanche photodiode (APD) ensures a constant value of photodiode sensitivity within wide range of temperature changes. The photoreceiver enables to receive 10-200 ns laser pulses.

Keywords: photoreceiver, rangefinder.

1. Introduction

Avalanche photodiodes are commonly used for detection of optical radiation of extremely low intensity. They are fundamental elements of photoreceivers. Figure 1 shows a block diagram of the photoreceiver used for detection of the radiation. The photoreceiver consists of main six blocks: photodiode, power supply and stabilisation of working point of APD system, preamplifier, filter, comparator, system for automatic control of comparator threshold, and DC/DC converter [1,2].

The EG&G avalanche photodiode of C-30645E type was used in the photoreceiver. It makes possible to receive the laser pulses with wavelength of 1550 nm [3]. Infrared

radiation of such a wavelength is recognised as eyesafe one. Fundamental system of detection unit is the APD and the signal preamplifier. Because the required band of the system is over 100 MHz and minimal photocurrent is ~ 100 nA, the APD, the preamplifier, and the comparator are situated in the separate complete module. In order to obtain high sensitivity of the photoreceiver, the preamplifier with a low level of noise should be applied. The comparator with an automatic control system of the threshold ensures generation of the output signal, always at the half of the amplitude of the received pulse. Power supply and APD working point stabilisation system keeps a constant sensitivity of the APD within wide range of temperature changes.

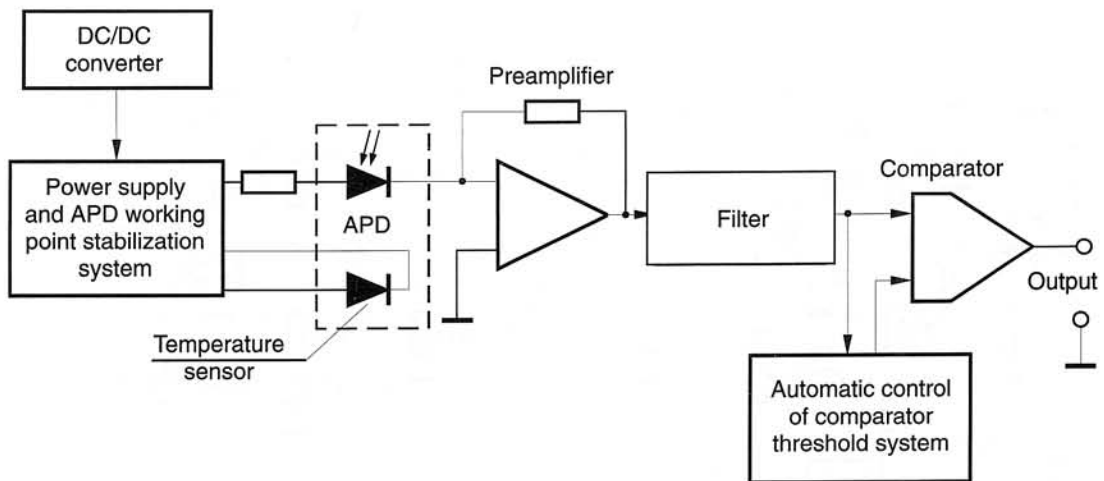

Fig. 1. Block diagram of the photoreceiver.

* e-mail: zbielecki@wat.waw.pl

2. Preamplifier

Schematic diagram of the preamplifier is shown in Fig. 2. A photocurrent from the APD is fed into the preamplifier. The broadband preamplifier is typical for applications up to 1 GHz [4]. Two-gate MOSFET transistors were used in the preamplifier. The first gate is polarised with a constant voltage ensuring transistor conduction and optimal amplification. The amplifier was designed and made using SMD technology. The photoreceiver's amplifier consists of three identical sections connected in series. Only one of them is shown in Fig. 2. Each section consists of a supply filter and three transistor-stages. The L40 coil, C33 and C34 capacitors ensure separation between particular amplifying stages and separation from the power supply system. In addition, a RC circuit (R4 C4) filters the first transistor of an amplifying stage. At each stage, the first two transistors operate with a common source and the second gate is polarised with a constant voltage. The third transistor is a separating source follower. The transistor Q1 operates in the common source system with a load in a drain of 470Ω (for variable component). The optimal working point is fixed by means of the potentiometer P1. The polarisation circuit of the gate G1 is decoupled to the mass by the capacitor C1. The input impedance of a single amplifying stage as well as the whole amplifier is determined mainly by the resistor R3 and it is equal to 100Ω . Coupling with the next transistor Q2, operating in a common source system, was accomplished by a series resonance circuit. It shapes the

frequency characteristics. The working point of the transistor Q3 should be fixed in such a way that G1 gate's potential is higher than the mass potential of at least 0.5 V .

The preamplifier was analysed by means of a computer simulation. Usually applied simulation programmes (SPICE type) are not adequate within the range of higher frequencies. Thus, for this system simulation the special Eclipse programme of the Arden Technologies Inc. was used.

As the results of numerical analyses the "s" parameters of the amplifier have been obtained in the frequency range from 1 MHz to 1 GHz. The most important parameter is the s21 matrix parameter. It gives information about the power amplification. In the frequency band from 10 MHz to 150 MHz (currently required range) a power amplification is enough to obtain the output voltage of 10 mV while the input photocurrent is equal to 100 nA. Such voltage level is sufficient for the MAX913 comparator. Strong limitation of a band above 300 MHz results from the applied correction circuit. This circuit decreases noise level of the input stage of the photoreceiver.

The next useful parameter is s11. The reflection coefficient s11 exceeds 10 dB. During the tests the generator characteristic impedance of 50Ω was used as a signal wave. It is close to the input impedance of the amplifier of 100Ω . Thus, the simulation results were close to the experimental results.

In the photoreceiver the filter was used ensuring the maximal value of signal-to-noise ratio of this photoreceiver.

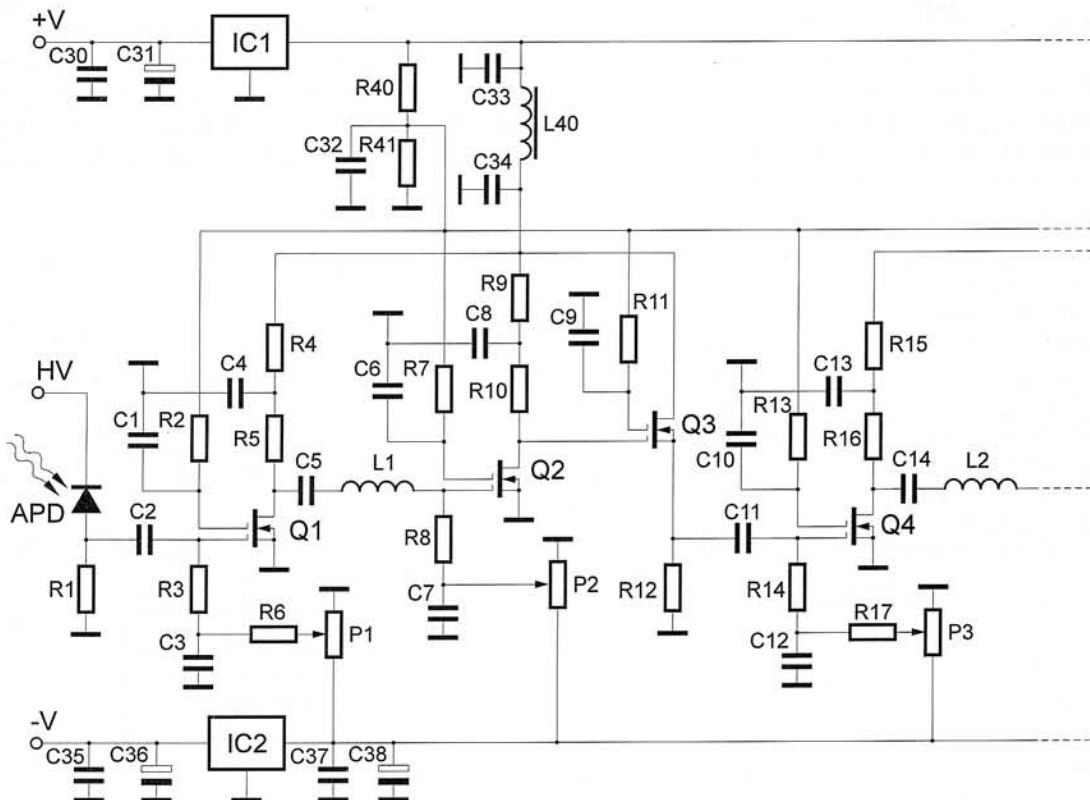

Fig. 2. Scheme of the first stage of the preamplifier.

3. Automatic control of the comparator level

The level of the signal reaching photoreceiver of the laser rangefinder depends on the reflection coefficient of an object. Figure 3(a) shows the signal reflected from the objects situated at the same distance to the rangefinder but having different reflection coefficients. The signal reflected from the object of the higher reflection coefficient reaches the amplitude V_2 but for the lower emission coefficient its amplitude is V_1 ($V_1 < V_2$). This signal is transmitted to one of the comparator's input. The reference voltage V_K was applied at the second comparator's input.

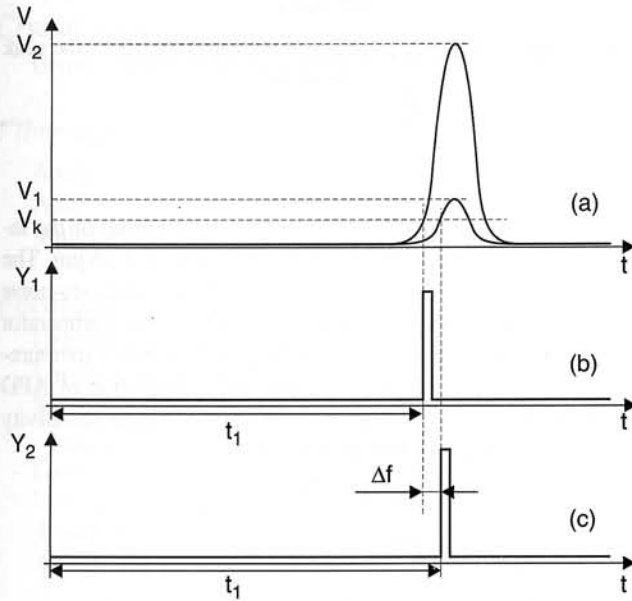

Fig. 3. Examples of comparator signals: signals at the comparator's input (a), the output signal Y_1 (b), the output signal Y_2 (c).

If the amplitude of the reflected pulse is higher than the amplitude comparator's level V_K there is a change in the state of the comparator output. For detection of the higher-amplitude signal this change occurs at the moment t_1 but for the lower-amplitude signal at the moment t_2 . As it can be seen in Fig. 3, the amplitude of the received pulses influences the moment of comparator switching, and it is a source of distance measurement error. In order to avoid such an error the system was designed, the scheme of which is shown in Fig. 4. This system consists of the peak detector IC1, D1, C1, and the comparator IC2. The capacitor C1 is charged with the current from the system output IC1, through the diode D1 up to the peak value of the received pulse. In the described system, the period of pulses repetition is significantly higher than their duration time. During the time between the two successive pulses, the capacitor C1 is discharged slowly through the resistor R1. The time constant of this circuit ($\tau = R_1 C_1$) is chosen in such a way that the amplitude of that pulse decreases up to 1/2 of its initial value before the next detected pulse. When

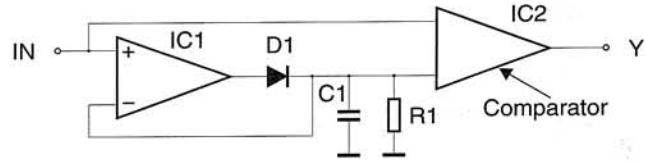

Fig. 4. System for automatic control of a comparator threshold.

the amplitude of the next pulse is higher than 1/2 value of the amplitude of the previous pulse, the change of the comparator's state is observed. In typical measuring conditions the same distance is measured several times, which ensures improvement in measurements accuracy due to the possibility of their averaging. Thus, the time of measurement is always fixed to the proper comparator threshold that amounts 1/2 of the pulses amplitude, i.e., in the place of the fastest signal changes ensuring the high accuracy of distance measurement. Figure 5 shows the voltages at the chosen points of the comparator circuit. As it can be seen in this figure, the moment when voltage reaches the comparator's output does not depend on amplitude of the output signal.

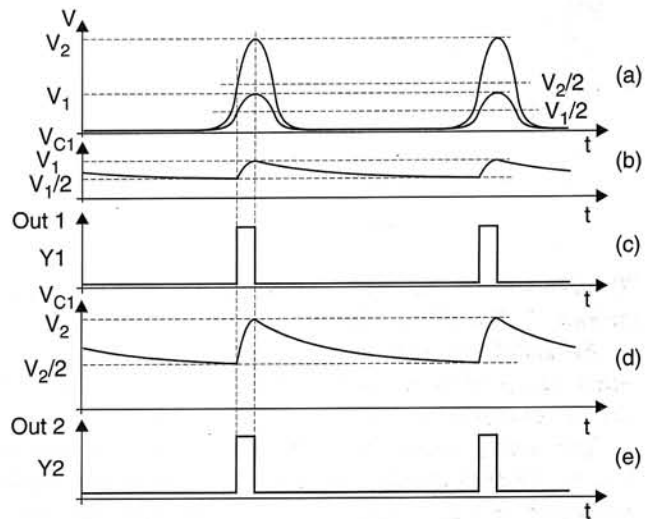

Fig. 5. Voltages at the chosen points of the comparator: signal V_1 or V_2 received at the input (a), voltage V_{C1} at the capacitor C1 when V_1 is applied at the input (b), output pulse (c), voltage V_{C1} at the capacitor C1 when V_2 is applied at the input (d), output pulse (e).

4. Photoreceiver measurements

The preamplifier was examined within the frequency range from 100 kHz to 200 MHz using a network analyser HP3563 type of the Hewlett-Packard firm. Frequency characteristics were measured for two parameters s_{11} and s_{21} (Figs. 6 and 7). The value of the reflection coefficient is such as predicted in computer simulation. This value decreases much more rapidly for the frequencies higher than

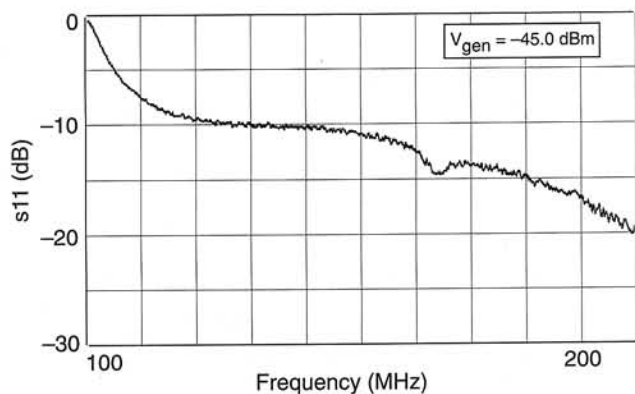

Fig. 6. s11 parameter of the preamplifier.

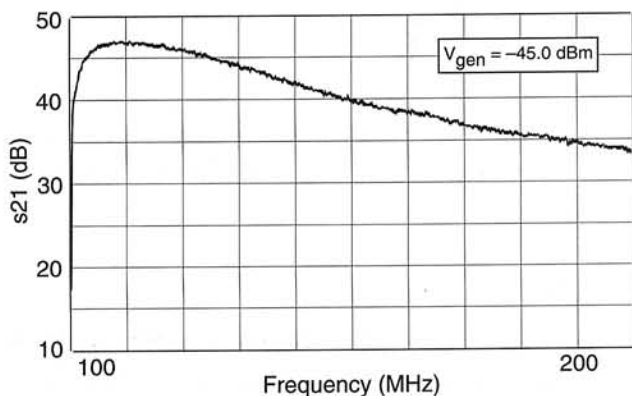

Fig. 7. s21 parameter of the preamplifier.

70 MHz but it is still within an acceptable range. The parameter s21 has also a value such as the predicted one.

An additional examination determining indirectly the output noises of the preamplifier was made. The parameter s21 was examined with no signal at the amplifier's output.

The noise parameters s21, for generator signal $U_{gen} = -45$ dBm and the parameter s21 without this signal are shown in Figs. 7 and 8. The voltages at characteristic points of the automatic control system are presented in Figs. 9 and 10.

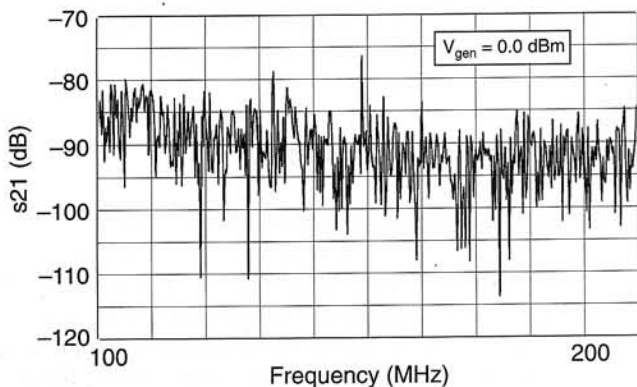

Fig. 8. Noise voltage at the amplifier output.

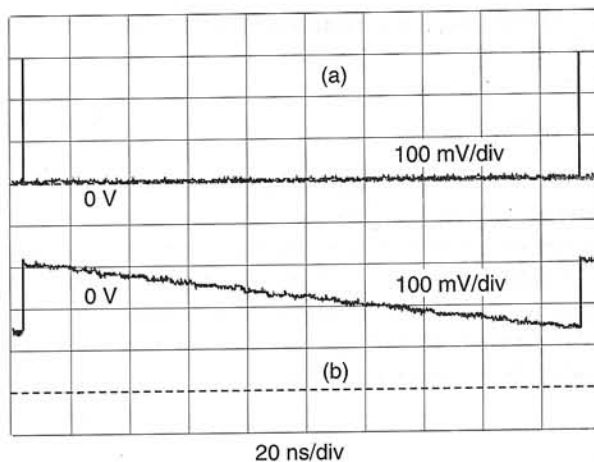

Fig. 9. Input voltage (a), voltage at the capacitor C1 of the peak detector (b).

5. Conclusions

The photoreceiver described here ensures reception of the laser pulses of 10 ns to 200 ns and wavelength of 1.55 μm . The applied filter allows obtaining the maximal signal-to-noise ratio and the system of automatic control of the comparator threshold enables to increase accuracy of a distance measurement. The system of power supply and stabilisation of APD working point gives constant value of photodiode sensitivity within wide range of temperature changes.

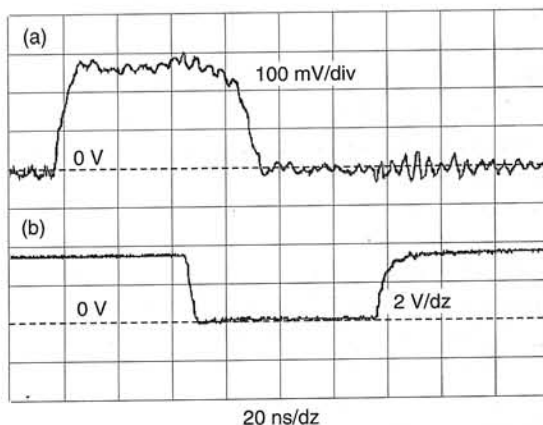

Fig. 10. Voltage at the non-inverting input of the amplifier IC1 (a), voltage at the comparator's output IC2 (b).

References

1. C.H. Hentschel, *Fiber Optics Handbook*, Hewlett-Packard GmbH, 1989.
2. Z. Bielecki, K. Chmielewski, H. Madura, and E. Powiada, "Electronic system distinguishing signal from background", Patent application no. PL 176480.
3. Z. Bielecki, "Analysis of operation conditions of avalanche photodiode on signal to noise ratio", *Opto-Electr. Rev.* **5**, 249 (1997).
4. Z. Bielecki, Report of grant no. 0T00A712 of the State Committee for Scientific Research, 1997.